

Installation,
Operation, and
Maintenance Manual

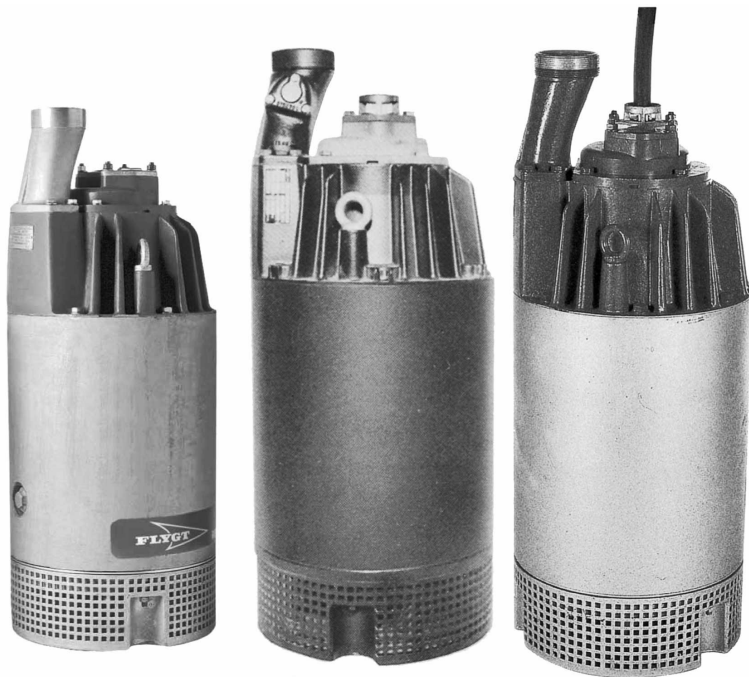

Flygt 2201

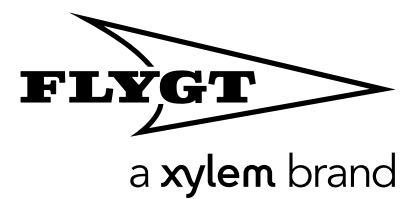

Table of Contents

Introduction and Safety	3
Introduction.....	3
Safety terminology and symbols.....	3
Product warranty.....	4
Spare parts.....	5
Safety.....	5
User safety.....	5
Hazardous liquids.....	6
Wash the skin and eyes.....	6
Ex-approved products.....	6
Guidelines for compliance.....	7
Permitted liquid level for ATEX.....	7
Monitoring equipment.....	7
MSHA requirements.....	7
Environmental safety.....	8
Transportation and Storage	9
Inspect the delivery.....	9
Inspect the package.....	9
Inspect the unit.....	9
Transportation guidelines.....	9
Precautions.....	9
Position and fastening.....	9
Lifting.....	9
Temperature ranges for transportation, handling and storage.....	9
Handling at freezing temperature.....	9
Unit in as-delivered condition.....	10
Lifting the unit out of liquid.....	10
Storage guidelines.....	10
Storage location.....	10
Long-term storage.....	10
Product Description	11
Products included.....	11
Pump design.....	11
Monitoring equipment.....	12
The data plate.....	12
The Ex approval plate.....	13
The MSHA approval plate.....	14
Product denomination.....	14
Installation	15
Install the pump.....	15
Sedimentation prevention.....	15
Discharge line requirements.....	15
Fasteners.....	16
Install with S-installation.....	16
Make the electrical connections.....	17
General precautions.....	17
Requirements.....	17
Cables.....	18
Earthing (Grounding).....	18

Earth (ground) conductor length.....	18
Connect the motor cable to the pump: Version code 011/320	18
Connect the motor cable to the pump: Version code 590/690	20
Cable charts.....	21
Connection locations.....	21
Color code standard.....	22
View of terminal board and sensor connections.....	23
Motor cable, stator leads and thermal contacts connection to terminal board.....	24
Check the impeller rotation.....	25
Operation.....	26
Precautions.....	26
Distance to wet areas.....	26
Noise level.....	26
Start the pump.....	26
Clean the pump.....	27
Maintenance.....	28
Precautions.....	28
Maintenance guidelines.....	28
Torque values.....	28
Service.....	29
Inspection.....	29
Major overhaul.....	31
Change the oil.....	31
Empty the oil.....	31
Fill with oil.....	32
Replace the impeller.....	32
Remove the impeller.....	32
Install the impeller.....	33
Adjust the impeller.....	34
Replace the diffuser.....	35
Troubleshooting.....	37
Introduction.....	37
The pump does not start.....	37
The pump does not stop when a level sensor is used.....	38
The pump starts-stops-starts in rapid sequence.....	38
The pump runs but the motor protection trips.....	39
The pump delivers too little or no water.....	39
Technical Reference.....	41
Application limits.....	41
Motor data.....	41
Specific motor data: Version code 011	41
Specific motor data: Version code 320/590/690	43
Dimensions and weights.....	44
Performance curves.....	46

Introduction and Safety

Introduction

Purpose of this manual

The purpose of this manual is to provide necessary information for:

- Installation
- Operation
- Maintenance



CAUTION:

Read this manual carefully before installing and using the product. Improper use of the product can cause personal injury and damage to property, and may void the warranty.

NOTICE:

Save this manual for future reference, and keep it readily available at the location of the unit.



Safety terminology and symbols

About safety messages

It is extremely important that you read, understand, and follow the safety messages and regulations carefully before handling the product. They are published to help prevent these hazards:

- Personal accidents and health problems
- Damage to the product
- Product malfunction

Hazard levels

Hazard level	Indication
 <p>DANGER:</p>	A hazardous situation which, if not avoided, will result in death or serious injury
 <p>WARNING:</p>	A hazardous situation which, if not avoided, could result in death or serious injury
 <p>CAUTION:</p>	A hazardous situation which, if not avoided, could result in minor or moderate injury

Hazard level	Indication
<p>NOTICE:</p>	<ul style="list-style-type: none"> • A potential situation which, if not avoided, could result in undesirable conditions • A practice not related to personal injury

Hazard categories

Hazard categories can either fall under hazard levels or let specific symbols replace the ordinary hazard level symbols.

Electrical hazards are indicated by the following specific symbol:



Electrical Hazard:

These are examples of other categories that can occur. They fall under the ordinary hazard levels and may use complementing symbols:

- Crush hazard
- Cutting hazard
- Arc flash hazard

Product warranty

Coverage

Xylem undertakes to remedy defects in products from Xylem under these conditions:

- The faults are due to defects in design, materials, or workmanship.
- The faults are reported to an Xylem representative within the warranty period.
- The product is used only under the conditions described in this manual.
- The monitoring equipment incorporated in the product is correctly connected and in use.
- All service and repair work is done by Xylem-authorized personnel.
- Genuine Xylem parts are used.
- Only Ex-approved spare parts and accessories authorized by Xylem are used in Ex-approved products.

Limitations

The warranty does not cover defects caused by these situations:

- Deficient maintenance
- Improper installation
- Modifications or changes to the product and installation made without consulting Xylem
- Incorrectly executed repair work
- Normal wear and tear

Xylem assumes no liability for these situations:

- Bodily injuries
- Material damages
- Economic losses

Warranty claim

Xylem products are high-quality products with expected reliable operation and long life. However, should the need arise for a warranty claim, then contact your Xylem representative.

Spare parts

Xylem guarantees that spare parts will be available for 10 years after the manufacture of this product has been discontinued.

Safety



WARNING:

- The operator must be aware of safety precautions to prevent physical injury.
 - Any pressure-containing device can explode, rupture, or discharge its contents if it is over-pressurized. Take all necessary measures to avoid over-pressurization.
 - Operating, installing, or maintaining the unit in any way that is not covered in this manual could cause death, serious personal injury, or damage to the equipment. This includes any modification to the equipment or use of parts not provided by Xylem. If there is a question regarding the intended use of the equipment, please contact an Xylem representative before proceeding.
 - This manual clearly identifies accepted methods for disassembling units. These methods must be adhered to. Trapped liquid can rapidly expand and result in a violent explosion and injury. Never apply heat to impellers, propellers, or their retaining devices to aid in their removal.
 - Do not change the service application without the approval of an authorized Xylem representative.
-



CAUTION:

You must observe the instructions contained in this manual. Failure to do so could result in physical injury, damage, or delays.

User safety

General safety rules

These safety rules apply:

- Always keep the work area clean.
- Pay attention to the risks presented by gas and vapors in the work area.
- Avoid all electrical dangers. Pay attention to the risks of electric shock or arc flash hazards.
- Always bear in mind the risk of drowning, electrical accidents, and burn injuries.

Safety equipment

Use safety equipment according to the company regulations. Use this safety equipment within the work area:

- Hard hat
- Safety goggles, preferably with side shields
- Protective shoes
- Protective gloves
- Gas mask
- Hearing protection

- First-aid kit
- Safety devices

NOTICE:

Never operate a unit unless safety devices are installed. Also see specific information about safety devices in other chapters of this manual.

Electrical connections

Electrical connections must be made by certified electricians in compliance with all international, national, state, and local regulations. For more information about requirements, see sections dealing specifically with electrical connections.

Hazardous liquids

The product is designed for use in liquids that can be hazardous to your health. Observe these rules when you work with the product:

- Make sure that all personnel who work with biologically hazardous liquids are vaccinated against diseases to which they may be exposed.
- Observe strict personal cleanliness.

Wash the skin and eyes

Follow these procedures for chemicals or hazardous fluids that have come into contact with your eyes or your skin:

Condition	Action
Chemicals or hazardous fluids in eyes	<ol style="list-style-type: none"> 1. Hold your eyelids apart forcibly with your fingers. 2. Rinse the eyes with eyewash or running water for at least 15 minutes. 3. Seek medical attention.
Chemicals or hazardous fluids on skin	<ol style="list-style-type: none"> 1. Remove contaminated clothing. 2. Wash the skin with soap and water for at least 1 minute. 3. Seek medical attention, if necessary.

Ex-approved products

Follow these special handling instructions if you have an Ex-approved unit.

Personnel requirements

These are the personnel requirements for Ex-approved products in potentially explosive atmospheres:

- All work on the product must be carried out by certified electricians and Xylem-authorized mechanics. Special rules apply to installations in explosive atmospheres.
- All users must know about the risks of electric current and the chemical and physical characteristics of the gas, the vapor, or both present in hazardous areas.
- Any maintenance for Ex-approved products must conform to international and national standards (for example, IEC/EN 60079-17).

Xylem disclaims all responsibility for work done by untrained and unauthorized personnel.

Product and product handling requirements

These are the product and product handling requirements for Ex-approved products in potentially explosive atmospheres:

- Only use the product in accordance with the approved motor data.
- You must fully submerge the Ex-approved product during normal operation. Dry running during service and inspection is only permitted outside the classified area.

- Before you start work on the product, make sure that the product and the control panel are isolated from the power supply and the control circuit, so they cannot be energized.
- Do not open the product while it is energized or in an explosive gas atmosphere.
- Make sure that thermal contacts are connected to a protection circuit according to the approval classification of the product, and that they are in use.
- Intrinsically safe circuits are normally required for the automatic level-control system by the level regulator if mounted in zone 0.
- The yield stress of fasteners must be in accordance with the approval drawing and the product specification.
- Do not modify the equipment without approval from an authorized Xylem representative.
- Only use parts that are provided by an authorized Xylem representative.

Guidelines for compliance

Compliance is fulfilled only when you operate the unit within its intended use. Do not change the conditions of the service without the approval of an Xylem representative. When you install or maintain explosion proof products, always comply with the directive and applicable standards (for example, IEC/EN 60079-14).

Permitted liquid level for ATEX

ATEX-approved products must be fully submerged according to the ATEX approval. Level-sensing equipment must be installed if the product can be operated at less than the minimum submersion depth.

Monitoring equipment

For additional safety, use condition-monitoring devices. Condition-monitoring devices include but are not limited to the following:

- Level indicators
- Temperature detectors

MSHA requirements

According to the Code of Federal Regulations, the following requirements must be fulfilled to maintain permissibility of this equipment:

Subject area	Requirements
General safety	<ul style="list-style-type: none"> • Frequent inspections must be made. • All electrical parts, portable cable, and wiring must be kept in a safe condition. • There must not be any openings into the casings of the electrical parts. • The machine frame must be effectively earthed (grounded). • Power wires must not be used for earthing (grounding). • The operating voltage must match the voltage rating of the motor.

Subject area	Requirements
Service and repair	<ul style="list-style-type: none"> • Inspections, service, and repairs are only allowed when the portable cable is disconnected from the power supply. • Work must be performed by trained personnel (preferably the manufacturer or agent) to ensure that the pump is restored to its original state of safety in regards to all flame-arresting paths. • Replacement parts must be exactly equal to those provided by the manufacturer. • When cable entries are disturbed on pump or control, they must be reassembled in the approved manner. <div style="display: flex; align-items: center; margin-top: 10px;">  <div> <p>DANGER: Failure to restore the permissible equipment to its original state of safety will void the MSHA approval. The creation of a safety hazard will subject the owner / operator of a mine to citations and penalties under the law.</p> </div> </div>
Fastenings	All bolts, nuts, screws, and threaded covers must be properly tightened and secured.
Cables	A flame-resistant portable cable must be used. It has to bear an MSHA-assigned identification number and be adequately protected by an automatic circuit-interrupting device. Special care must be taken in handling the cable to avoid mechanical damage and wear.
Operation	Poly-Life® equipped products must not be operated dry in hazardous areas.

Environmental safety

The work area

Always keep the station clean to avoid and/or discover emissions.

Waste and emissions regulations

Observe these safety regulations regarding waste and emissions:

- Appropriately dispose of all waste.
- Handle and dispose of the processed liquid in compliance with applicable environmental regulations.
- Clean up all spills in accordance with safety and environmental procedures.
- Report all environmental emissions to the appropriate authorities.



WARNING:

Do NOT send the product to the Xylem manufacturer if it has been contaminated by any nuclear radiation. Inform Xylem so that accurate actions can take place.

Electrical installation

For electrical installation recycling requirements, consult your local electric utility.

Transportation and Storage

Inspect the delivery

Inspect the package

1. Inspect the package for damaged or missing items upon delivery.
2. Note any damaged or missing items on the receipt and freight bill.
3. File a claim with the shipping company if anything is out of order.
If the product has been picked up at a distributor, make a claim directly to the distributor.

Inspect the unit

1. Remove packing materials from the product.
Dispose of all packing materials in accordance with local regulations.
2. Inspect the product to determine if any parts have been damaged or are missing.
3. If applicable, unfasten the product by removing any screws, bolts, or straps.
For your personal safety, be careful when you handle nails and straps.
4. Contact your sales representative if anything is out of order.

Transportation guidelines

Precautions



WARNING:

- Stay clear of suspended loads.
 - Observe accident prevention regulations in force.
-

Position and fastening

The unit can be transported either horizontally or vertically. Make sure that the unit is securely fastened during transportation, and cannot roll or fall over.

Lifting



WARNING:

- Crush hazard. The unit and the components can be heavy. Use proper lifting methods and wear steel-toed shoes at all times.
 - Lift and handle the product carefully, using suitable lifting equipment.
 - The product must be securely harnessed for lifting and handling. Use eyebolts or lifting lugs if available.
 - Always lift the unit by its lifting handle. Never lift the unit by the motor cable or by the hose.
 - Do not attach sling ropes to shaft ends.
-

Temperature ranges for transportation, handling and storage

Handling at freezing temperature

At temperatures below freezing, the product and all installation equipment, including the lifting gear, must be handled with extreme care.

Make sure that the product is warmed up to a temperature above the freezing point before starting up. Avoid rotating the impeller/propeller by hand at temperatures below the freezing point. The recommended method to warm the unit up is to submerge it in the liquid which will be pumped or mixed.

NOTICE:

Never use a naked flame to thaw the unit.

Unit in as-delivered condition

If the unit is still in the condition in which it left the factory - all packing materials are undisturbed - then the acceptable temperature range during transportation, handling and storage is: -50°C (-58°F) to +60°C (+140°F).

If the unit has been exposed to freezing temperatures, then allow it to reach the ambient temperature of the sump before operating.

Lifting the unit out of liquid

The unit is normally protected from freezing while operating or immersed in liquid, but the impeller/propeller and the shaft seal may freeze if the unit is lifted out of the liquid into a surrounding temperature below freezing.

Units equipped with an internal cooling system are filled with a mixture of water and 30% glycol. This mixture remains a flowing liquid at temperatures down to -13°C (9°F). Below -13°C (9°F), the viscosity increases such that the glycol mixture will lose its flow properties. However, the glycol-water mixture will not solidify completely and thus cannot harm the product.

Follow these guidelines to avoid freezing damage:

1. Empty all pumped liquid, if applicable.
2. Check all liquids used for lubrication or cooling, both oil and water-glycol mixtures, for the presence of water. Change if needed.

Storage guidelines

Storage location

The product must be stored in a covered and dry location free from heat, dirt, and vibrations.

NOTICE:

- Protect the product against humidity, heat sources, and mechanical damage.
 - Do not place heavy weights on the packed product.
-



Long-term storage

If the unit is stored more than 6 months, the following apply:

- Before operating the unit after storage, it must be inspected with special attention to the seals and the cable entry.
- The impeller/propeller must be rotated every other month to prevent the seals from sticking together.

Product Description

Products included

Pump model	Approvals
2201.011 2201.320	Standard
2201.590	European Norm <ul style="list-style-type: none"> • ATEX Directive • EN 1127-1, EN 50014, EN 50018, EN 50019 •  II 2G EEx de IIB T3 MSHA (Mine Safety and Health Administration, USA): 30CFR Part 18, Approval number X/P-3400-1
2201.690	European Norm <ul style="list-style-type: none"> • ATEX Directive • EN 1127-1, EN 50014, EN 50018 •  I M2 EEx d I International Norm; not for EU member countries <ul style="list-style-type: none"> • IECEx scheme • IEC 60079-0, IEC 60079-1 • Ex d I

Pump design

The pump is submersible, and driven by an electric motor.

Intended use

The product is intended for moving waste water, sludge, raw and clean water. Always follow the limits given in [Application limits](#) (page 41). If there is a question regarding the intended use of the equipment, please contact an Xylem representative before proceeding.



WARNING:

In explosive or flammable environments, only use Ex- or MSHA-approved pumps.

NOTICE:

Do NOT use the pump in highly corrosive liquids.

For information about pH, see [Application limits](#) (page 41).

Particle size

The pump can handle liquid containing particles that correspond to the holes in the strainer.

Number of holes	Hole dimensions
LT/MT: 212	10×10 mm (0.4×0.4 in.)
HT: 574	15×45 mm (0.6×1.77 in.)

Pressure class

Version code 011: LT	Low head
MT	Medium head
HT	High head

Impeller type

B	Wear resistant
---	----------------

Poly-Life®

Version code 011/320: The pump is available with Poly-Life® polyurethane wear parts for extra resistance.

Monitoring equipment

The following applies to the monitoring equipment of the pump:

- The stator incorporates thermal contacts connected in series that activate the alarm at overtemperature.
- The thermal contacts open at 125°C (257°F) and close at 70°C (160°F).

The data plate

The data plate is a metal label located on the main body of the products. The data plate lists key product specifications. Specially approved products also have an approval plate.

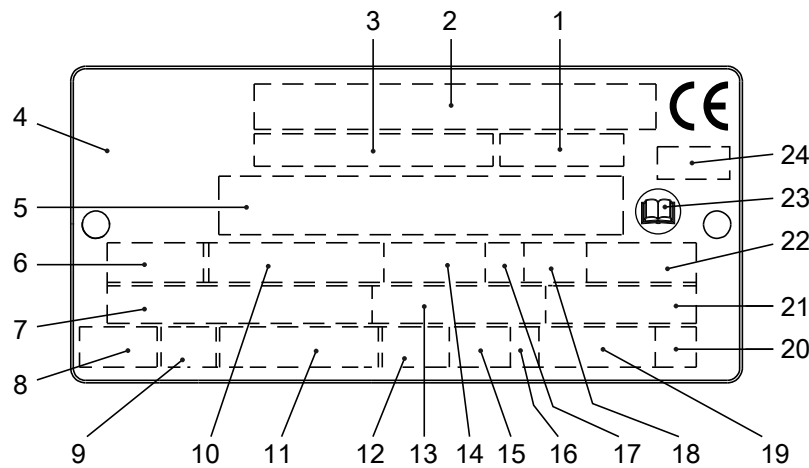

1. Curve code/Propeller code
2. Serial number, see [Product denomination](#) (page 14)
3. Product number
4. Country of origin
5. Additional information
6. Phase; type of current; frequency
7. Rated voltage
8. Thermal protection
9. Thermal class
10. Rated shaft power
11. International standard
12. Degree of protection
13. Rated current
14. Rated speed
15. Maximum submergence
16. Direction of rotation: L=left, R=right
17. Duty class
18. Duty factor
19. Product weight
20. Locked rotor code letter
21. Power factor

WS006257A

- 22. Maximum ambient temperature
- 23. Read installation manual
- 24. Notified body. Only for EN-approved Ex-products

Figure 1: The data plate

The Ex approval plate

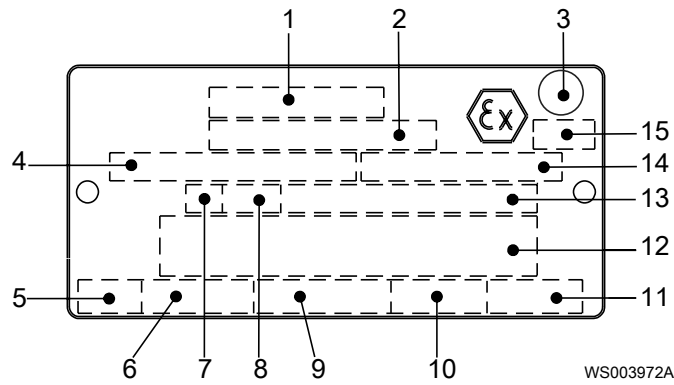

- 1. Approval
- 2. Approval authority and approval number
- 3. Approval for Class I
- 4. Approved drive unit
- 5. Stall time
- 6. Starting current/Rated current
- 7. Duty class
- 8. Duty factor
- 9. Input power
- 10. Rated speed
- 11. Controller
- 12. Additional information
- 13. Maximum ambient temperature
- 14. Serial number
- 15. ATEX marking

Figure 2: EN

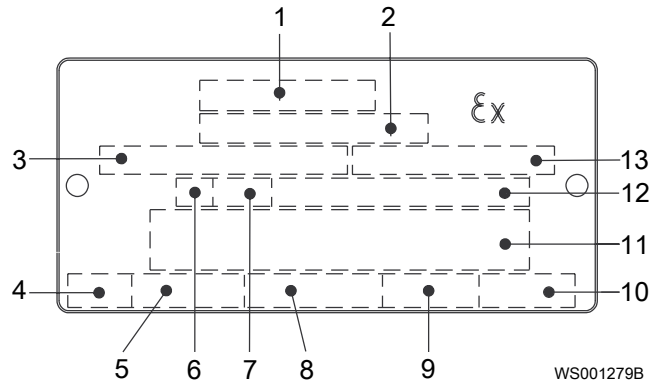
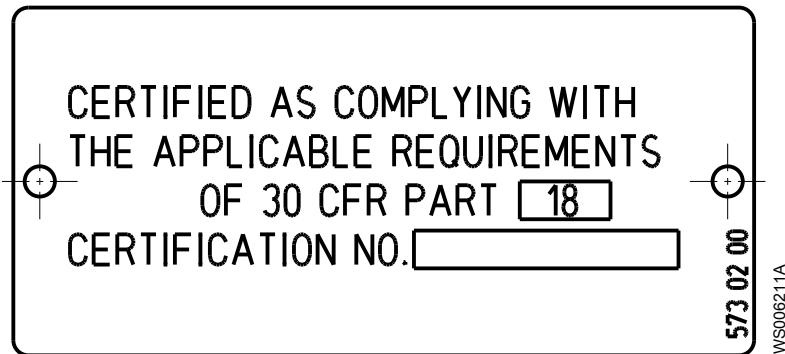

Figure 3: IEC

- 1. Approval
- 2. Approval authority + approval number
- 3. Approved for drive unit
- 4. Stall time
- 5. Starting current/Rated current
- 6. Duty class
- 7. Duty factor
- 8. Input power
- 9. Rated speed
- 10. Controller

- 11. Additional information
- 12. Max. ambient temperature
- 13. Serial number

The MSHA approval plate



Product denomination

Sales denomination

The sales denomination consists of the four-digit sales code and two letters that indicate the hydraulic end and type of installation.

This is an example of a sales denomination, and an explanation of its parts.

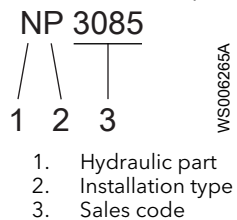

Product code

The product code consists of nine characters divided into two parts.

This is an example of a product code, and an explanation of its parts.

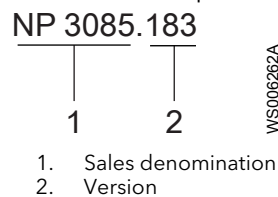

Serial number

The serial number is used for identification of an individual product, and is divided into four parts.

This is an example of a serial number, and an explanation of its parts.

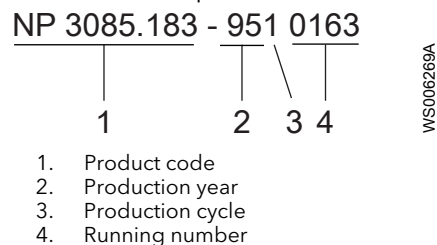

Installation

Install the pump



WARNING:

- Electrical shock hazard. Check that the cable and cable entry have not been damaged during transport before installing the pump.
- Make sure that the unit cannot roll or fall over and injure people or damage property.
- Do not install CSA-approved products in locations that are classified as hazardous in the national electric code, ANSI/NFPA 70-2005.
- Do not install the starter equipment in an explosive zone unless it is explosion-proof rated.

NOTICE:

- Never force piping to make a connection with a pump.

These requirements apply:

- Use the pump dimensional drawing in order to ensure proper installation.
- Provide a suitable barrier around the work area, for example, a guard rail.
- Check the explosion risk before you weld or use electric hand tools.
- Remove all debris from the inlet piping system before you install the pump.
- Always check the impeller rotation before lowering the pump into the pumped liquid.

Sedimentation prevention

In order to avoid sedimentation when the pumped liquid contains solid particles, the velocity of the liquid in the discharge line must exceed a certain value. Choose applicable minimum velocity from the table, and choose proper dimension of the discharge line accordingly.

Mixture	Minimum velocity, meter per second (feet per second)
Water + coarse gravel	4 (13)
Water + gravel	3.5 (11)
Water + sand, particle size <0.6 mm (0.024 in)	2.5 (8.2)
Water + sand, particle size <0.1 mm (0.004 in)	1.5 (4.9)

For more permanent installations with a heavily contaminated pumped liquid, a settling pump-sump is recommended.

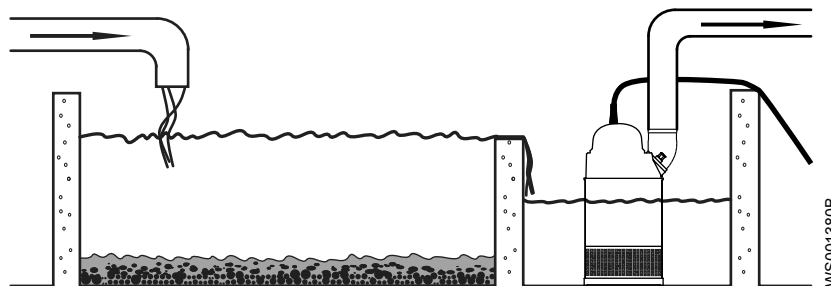
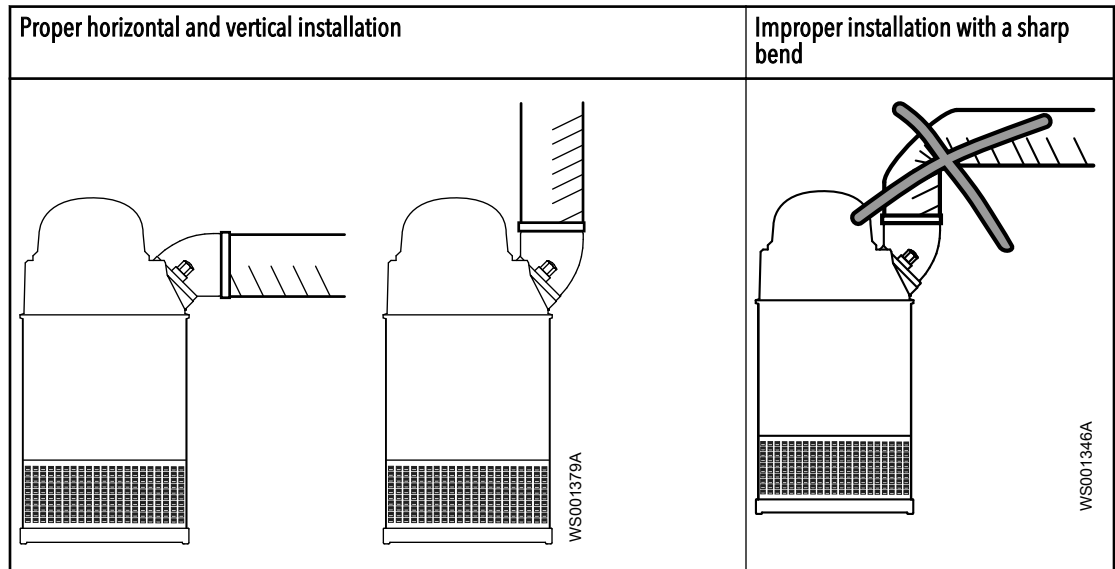

Figure 4: Settling pump-sump

Discharge line requirements

The discharge line can be run vertically or horizontally, but must be without sharp bends.



Fasteners

**WARNING:**

- Only use fasteners of the proper size and material.
- Replace all corroded fasteners.
- Make sure that all fasteners are properly tightened and that there are no missing fasteners.

Install with S-installation

In the S-installation, the pump is transportable and intended to operate either completely or partially submerged in the pumped liquid. The pump is equipped with a connection for hose or pipe.

These requirements and instructions only apply when the installation is made according to the dimensional drawing.

1. Run the cable so that it has no sharp bends. Make sure that it is not pinched, and cannot be sucked into the pump inlet.
2. Connect the discharge line.
3. Lower the pump into the sump.
4. Place the pump on the base and make sure it cannot fall over or sink.

Alternatively, the pump can be suspended with a lifting chain just above the sump bottom. Make sure that the pump cannot rotate at startup or during operation.

5. Connect the motor cable and the starter and monitoring equipment according to the separate instructions.

Make sure that the impeller rotation is correct. For more information, see [Check the impeller rotation](#) (page 25).

Make the electrical connections

General precautions



Electrical Hazard:

- A certified electrician must supervise all electrical work. Comply with all local codes and regulations.
- Before starting work on the unit, make sure that the unit and the control panel are isolated from the power supply and cannot be energized. This applies to the control circuit as well.
- Leakage into the electrical parts can cause damaged equipment or a blown fuse. Keep the end of the motor cable above the liquid level.
- Make sure that all unused conductors are insulated.
- There is a risk of electrical shock or explosion if the electrical connections are not correctly carried out or if there is fault or damage on the product.



WARNING:

Do not install the starter equipment in an explosive zone unless it is explosion-proof rated.



CAUTION:

If the pump is equipped with automatic level control and/or internal contactor, there is a risk of sudden restart.

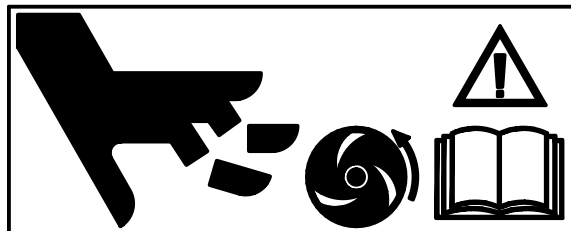

WS006209A

Requirements

These general requirements apply for electrical installation:

- The supply authority must be notified before installing the pump if it will be connected to the public mains. When the pump is connected to the public power supply, it may cause flickering of incandescent lamps when started.
- The mains voltage and frequency must agree with the specifications on the data plate. If the pump can be connected to different voltages, then the connected voltage is specified by a yellow sticker close to the cable entry.
- The fuses and circuit breakers must have the proper rating, and the pump overload protection (motor protection breaker) must be connected and set to the rated current according to the data plate and if applicable the cable chart. The starting current in direct-on-line start can be up to six times higher than the rated current.
- The fuse rating and the cables must be in accordance with the local rules and regulations.
- If intermittent operation is prescribed, then the pump must be provided with monitoring equipment supporting such operation.
- The thermal contacts/thermistors must be in use.

Cables

These are the requirements to follow when you install cables:

- The cables must be in good condition, not have any sharp bends, and not be pinched.
- The sheathing must not be damaged and must not have indentations or be embossed (with markings, etc.) at the cable entry.
- The cable entry seal sleeve and washers must conform to the outside diameter of the cable.
- The minimum bending radius must not be below the accepted value.
- If using a cable which has been used before, a short piece must be peeled off when refitting it so that the cable entry seal sleeve does not close around the cable at the same point again. If the outer sheath of the cable is damaged, then replace the cable. Contact an Xylem service shop.
- The voltage drop in long cables must be taken into account. The drive unit's rated voltage is the voltage measured at the cable connection point in the pump.

Earthing (Grounding)



Electrical Hazard:

- You must earth (ground) all electrical equipment. This applies to the pump equipment, the driver, and any monitoring equipment. Test the earth (ground) lead to verify that it is connected correctly.
 - If the motor cable is jerked loose by mistake, the earth (ground) conductor should be the last conductor to come loose from its terminal. Make sure that the earth (ground) conductor is longer than the phase conductors. This applies to both ends of the motor cable.
 - Risk of electrical shock or burn. You must connect an additional earth- (ground-) fault protection device to the earthed (grounded) connectors if persons are likely to come into physical contact with the pump or pumped liquids.
-

Earth (ground) conductor length

The earth (ground) conductor must be 100 mm (4.0 in.) longer than the phase conductors in the junction box of the unit.

Connect the motor cable to the pump: Version code 011/320



CAUTION:

Leakage into the electrical parts can cause damaged equipment or a blown fuse. Keep the end of the motor cable above the liquid level.

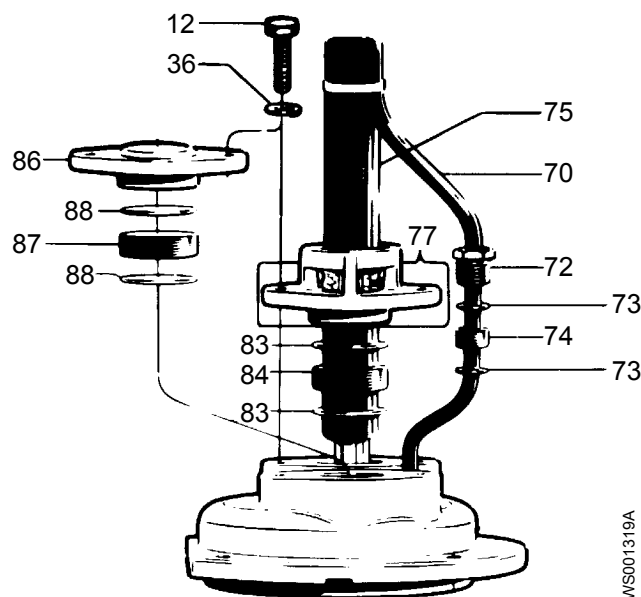

Part	Description
12	Screws
72	Gland nut
125	Cover

Figure 5: Cable entry for version code 320

- Check the data plate to see which connections are required for the power supply:
 - Y
 - D
 - Y serial
 - Y parallel
 - Y/D
- Arrange the connections on the terminal board in accordance with the required power supply.
Do not use links (jumper strips) with the Y/D start.
Do not use links (jumper strips) with the 9 stator leads tandem-coupling.
- Connect the motor conductors (U1, V1, W1, and earth (ground)) to the terminal board.
- Make sure that the pump is correctly connected to earth (ground).
- Make sure that any thermal contacts incorporated in the pump are properly connected to the terminal board.
- Install the cover.
- Version code 011: Fasten the nuts on the entrance flange so that the cable insertion assembly bottoms out.
- Version code 320: Fasten the screws and the gland nut on the entrance flange so that the cable insertion assembly bottoms out.

After you have connected the motor cable to the pump, connect the motor cable and the control cable to the starter equipment.

WARNING:

Do not install the starter equipment in an explosive zone unless it is explosion-proof rated.



Three thermal contacts are incorporated in the stator. They are normally closed.

Thermal contacts must never be exposed to voltages higher than 250 V, breaking current maximum 6 A at a power factor 0.6. It is recommended that the thermal contacts are connected to 24 V over a separate fuse to protect any other automatic equipment.

Connect the motor cable to the pump: Version code 590/690

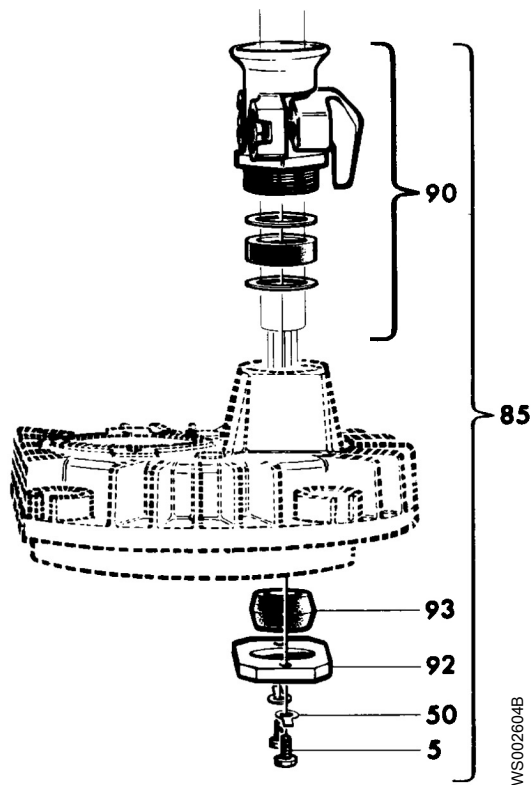

Part	Description
5	Screw
50	Lock washer
90	Cable entry
92	Gland flange
93	Seal sleeve

Figure 6: Cable entry

1. Insert the motor cable.
25-30 mm (0.9-1.2 in.) of the jacket must be on the inside of the cover.
2. Tighten the cable entry so that the seal sleeve is compressed and seals between the motor cable and the cover.
The cable entry is threaded with M36, M48 and M55.
3. Twist together the earth (ground) leads into a bundle and slip an insulating tube over the intertwined leads.
The earth (ground) leads are located concentrically around each phase lead.
4. Fit the gland flange:

- a) Fit it with the largest diameter of the hole facing the inside of the cover.
- b) Tighten the screws, but leave 1 mm (0.04 in.) of clearance between the cover and the gland flange.
- c) Lock the screws with the lock washers.
5. Connect the leads.
6. Connect the control cable between the terminal board (H1 and H2) and the control circuit of the starter.
7. Fit and tighten the cover.
- Check, through the inspection hole, that no leads are pinched.
8. Fit and tighten the inspection cover.
9. Connect the pump to earth (ground) with an external earth (ground) lead on the top of the cover.

Cable charts

Connection locations

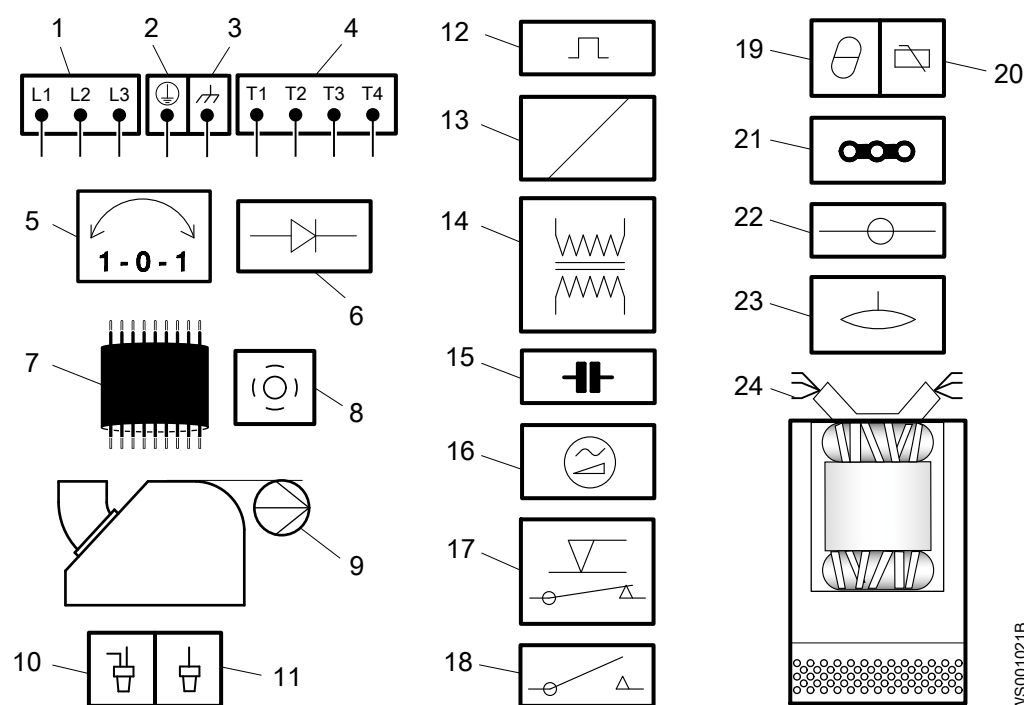

1	Starter equipment and main leads (L1, L2, L3)	13	Coil
2	Earth (ground)	14	Transformer
3	Functional ground	15	Capacitor
4	Control leads (T1, T2, T3, T4)	16	Softstarter
5	Phase shifter	17	Level regulator
6	Diode	18	Contactor, start relay or thermal relay
7	Motor cable, minimum 20 m (66 ft.)	19	Thermal detector in stator
8	Screen	20	Thermal detector in main bearing
9	Pump	21	Jumper
10	Crimp connection	22	Terminal board, terminal plate
11	Crimp isolation	23	Leakage sensor

12	Motor protector	24	Stator leads (U1, U2, U5, U6, V1, V2, V5, V6, W1, W2, W5, W6, Z1, Z5, Z6)
----	-----------------	----	---

Color code standard

Code	Description
BN	Brown
BK	Black
WH	White
OG	Orange
GN	Green
GNYE	Green-Yellow
RD	Red
GY	Grey
BU	Blue
YE	Yellow

View of terminal board and sensor connections

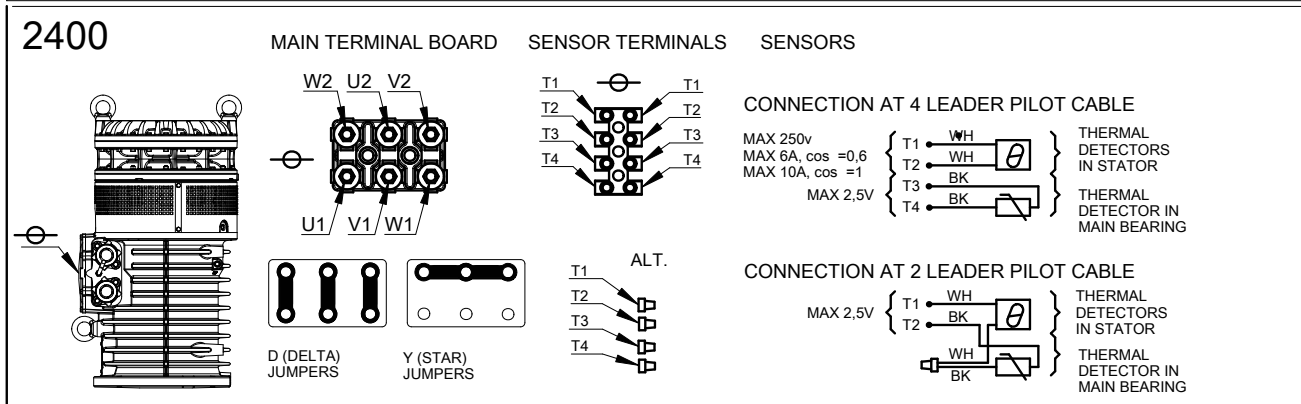
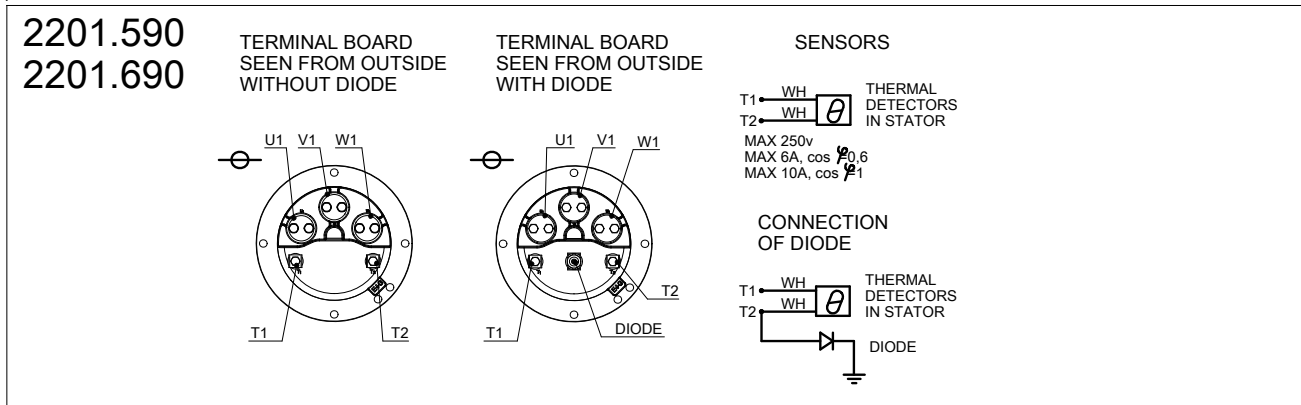
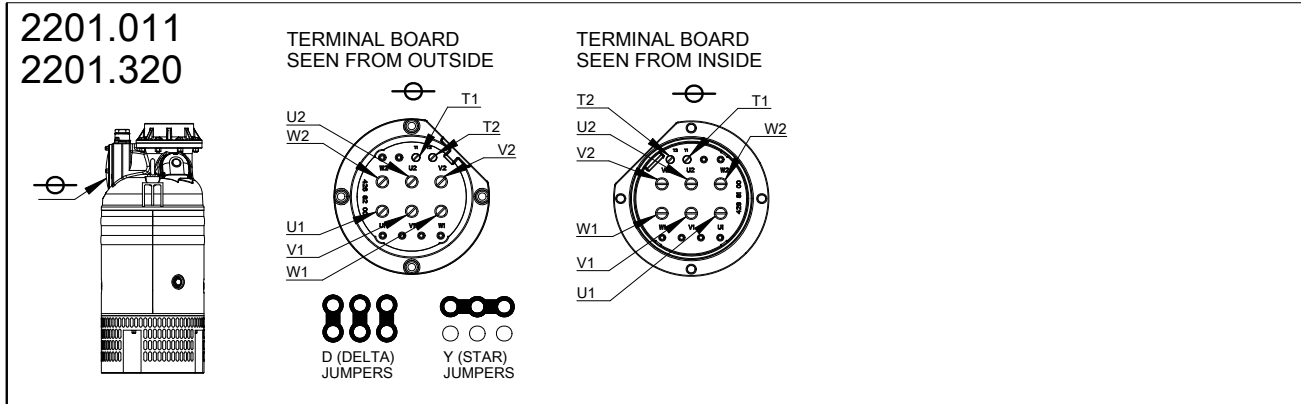
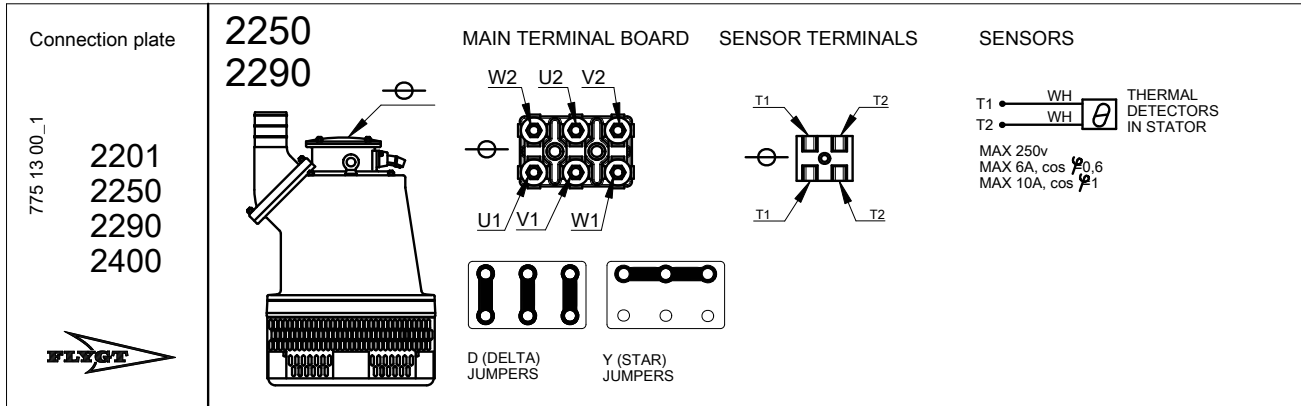

WS004538A

Motor cable, stator leads and thermal contacts connection to terminal board

775 13 00_1

2201

2250

2290

2400

SYMBOLS AND DENOMINATIONS

BN=Brown	⊖=Terminal board
BK=Black	⊖=Screen
WH=White	⊕=Ground
OG=Orange	⏏=Functional ground
GN=Green	⏏=Crimp connection
GNYE=Green-Yellow	⏏=Crimp isolation
RD=Red	
GY=Grey	
BU=Blue	
YE=Yellow	

GC= Ground check
A = Cable dimension in cable specification

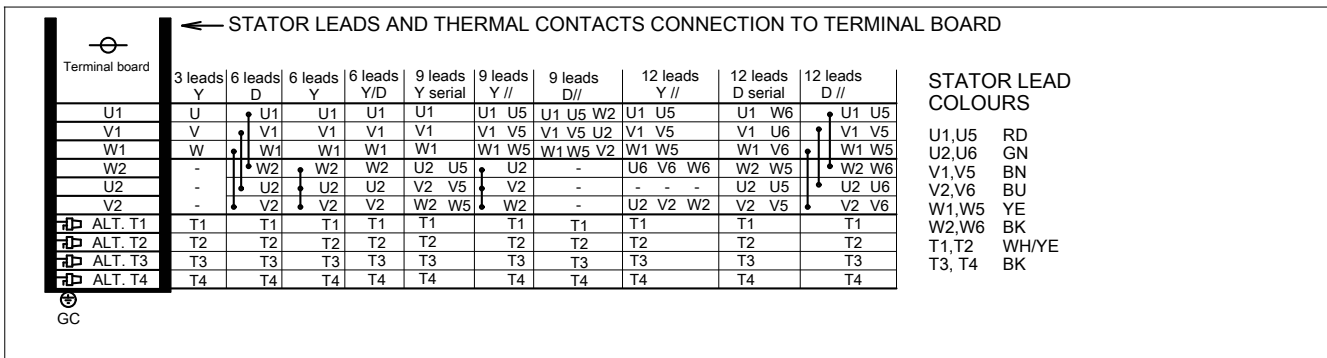
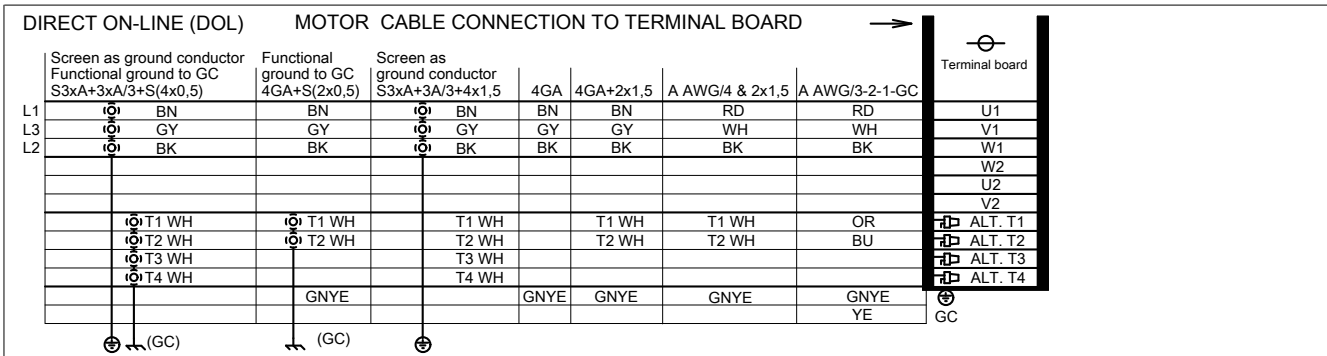
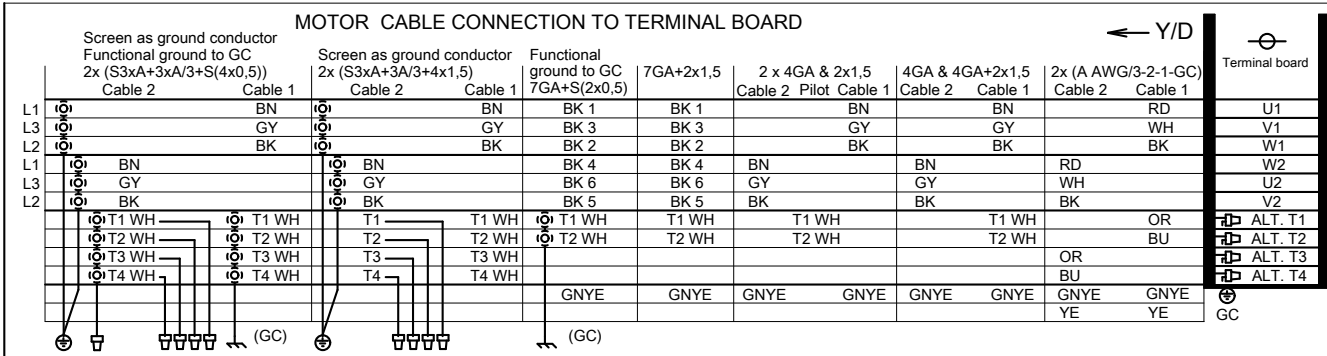

Check the impeller rotation



WARNING:

The starting jerk can be powerful.

Check the direction of rotation each time the cable has been re-connected and after phase or total supply failure.

1. Start the motor.
2. Stop the motor.
3. Check that the impeller rotates in the correct direction.

The correct direction of impeller rotation is clockwise when you look at the pump from above. When started, the pump will react in the opposite direction to the impeller rotation.

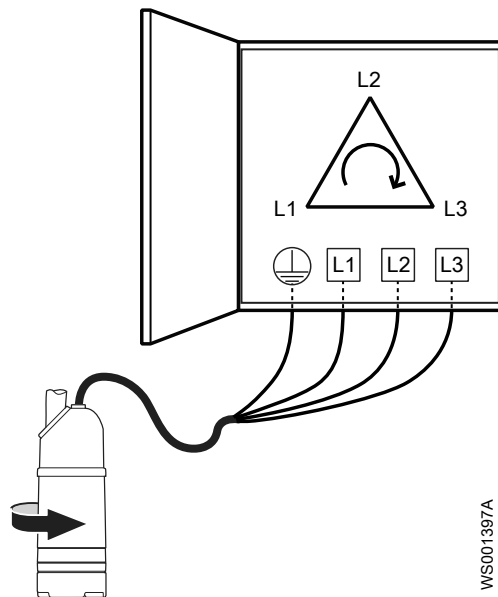

WS001397A

Figure 7: Start reaction

4. If the impeller rotates in the wrong direction, then do the following:
 - If the motor has a 3-phase connection, then transpose two phase conductors and repeat this procedure from step 1.

For 3-phase pumps with external starters or without built-in motor protection, the phases must be shifted on the output terminal of the starter.

Operation

Precautions



WARNING:

- Never operate the pump without safety devices installed.
- Never operate the pump with the discharge valve closed.
- Make sure you have a clear path of retreat.
- Never work alone.



CAUTION:

If the pump is equipped with automatic level control and/or internal contactor, there is a risk of sudden restart.

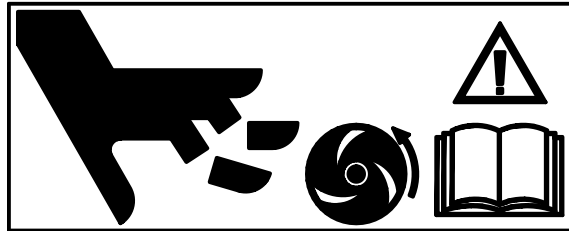

WS006209A

Distance to wet areas



Electrical Hazard:

Risk of electrical shock. Make sure no one gets closer than 20 m (65 ft.) to the unit when being in contact with the pumped or mixed liquid.



Electrical Hazard:

Risk of electrical shock. This unit has not been investigated for use in swimming pools. If used in connection with swimming pools special safety regulations apply.

Noise level

NOTICE:

The noise level of the product is lower than 70 dB. However, the noise level of 70 dB may be exceeded in some installations and at certain operating points on the performance curve. Make sure that you understand the noise level requirements in the environment where the pump is installed. Failure to do so may result in hearing loss or violation of local laws.

Start the pump



WARNING:

- If you need to work on the pump, make sure that it is isolated from the power supply and cannot be energized.
 - Make sure that the unit cannot roll or fall over and injure people or damage property.
 - In some installations, the pump and the surrounding liquid may be hot. Bear in mind the risk of burn injuries.
 - Make sure nobody is close to the unit when it is started. The unit will jerk in the opposite direction of the impeller rotation.
 - During operation the Ex-approved product must be fully submerged.
-

NOTICE:

Make sure that the rotation of the impeller is correct. For more information, see Check the impeller rotation.

1. Check the oil level in the oil housing.
2. Remove the fuses or open the circuit breaker, and check that the impeller can be rotated freely.
3. Check that the monitoring equipment (if any) works.
4. Check that the impeller rotation is correct.
5. Start the pump.

Clean the pump

The pump must be cleaned if it has been running in very dirty water. If clay, cement or other similar dirt is left in the pump it may clog the impeller and seal, preventing the pump from working.

Let the pump run for a while in clean water, or flush it through the discharge connection.

Maintenance

Precautions



WARNING:

- Always follow safety guidelines when working on the product. See [Introduction and Safety](#) (page 3).
- Disconnect and lock out electrical power before installing or servicing the pump.
- Make sure that the unit cannot roll or fall over and injure people or damage property.
- Rinse the unit thoroughly with clean water before working on the unit.
- Rinse the components in water after dismantling.

Make sure that you follow these requirements:

- Check the explosion risk before you weld or use electrical hand tools.
- Allow all system and pump components to cool before you handle them.
- Make sure that the product and its components have been thoroughly cleaned.
- Do not open any vent or drain valves or remove any plugs while the system is pressurized. Make sure that the pump is isolated from the system and that pressure is relieved before you disassemble the pump, remove plugs, or disconnect piping.

Maintenance guidelines

During maintenance and before reassembly, always remember to perform these tasks:

- Clean all parts thoroughly, particularly O-ring grooves.
- Change all O-rings, gaskets, and seal washers.
- Lubricate all springs, screws, and O-rings with grease.

During reassembly, always make sure that existing index markings are in line.

The reassembled drive unit must always be insulation-tested and the reassembled pump must always be test-run before normal operation.

Torque values

All screws and nuts must be lubricated to achieve correct tightening torque. Screws that are screwed into stainless steel must have the threads coated with suitable lubricants to prevent seizing.

If there is a question regarding the tightening torques, please contact a sales representative.

Screws and nuts

Table 1: Stainless steel, A2 and A4, torque Nm (ft-lbs)

Property class	M4	M5	M6	M8	M10	M12	M16	M20	M24	M30
50	1.0 (0.74)	2.0 (1.5)	3.0 (2.2)	8.0 (5.9)	15 (11)	27 (20)	65 (48)	127 (93.7)	220 (162)	434 (320)
70, 80	2.7 (2)	5.4 (4)	9.0 (6.6)	22 (16)	44 (32)	76 (56)	187 (138)	364 (268)	629 (464)	1240 (915)

Property class	M4	M5	M6	M8	M10	M12	M16	M20	M24	M30
100	4.1 (3)	8.1 (6)	14 (10)	34 (25)	66 (49)	115 (84.8)	248 (183)	481 (355)	–	–

Table 2: Steel, torque Nm (ft-lbs)

Property class	M4	M5	M6	M8	M10	M12	M16	M20	M24	M30
8.8	2.9 (2.1)	5.7 (4.2)	9.8 (7.2)	24 (18)	47 (35)	81(60)	194 (143)	385 (285)	665 (490)	1310 (966.2)
10.9	4.0 (2.9)	8.1 (6)	14 (10)	33 (24)	65 (48)	114 (84)	277 (204)	541 (399)	935 (689)	1840 (1357)
12.9	4.9 (3.6)	9.7 (7.2)	17 (13)	40 (30)	79 (58)	136 (100)	333 (245)	649 (480)	1120 (825.1)	2210 (1630)

Hexagon screws with countersunk heads

For hexagon socket head screws with countersunk head, maximum torque for all property classes must be 80% of the values for property class 8.8 above.

Service

Regular inspection and service of the pump ensures more reliable operation.

Type of service	Purpose	Inspection interval
Inspection	To prevent operational interruptions and machine breakdown. Measures to secure performance and pump efficiency are defined and decided for each individual application. It can include such things as impeller trimming, wear part control and replacement, control of zinc-anodes and control of the stator.	Twice a year
Major overhaul	To secure a long operating lifetime for the product. It includes replacement of key components and the measures taken during an inspection.	Every year, under normal operating conditions

NOTICE:

Shorter intervals may be required when the operating conditions are extreme, for example with very abrasive or corrosive applications or when the liquid temperatures exceed 40°C (104°F).

Inspection

Regular inspection and service of the pump ensures more reliable operation.

Service item	Action
Visible parts on the pump and installation	<ol style="list-style-type: none"> 1. Check that all screws, bolts, and nuts are properly tightened. 2. Check the condition of lifting handles, eye bolts, ropes, chains, and wires. 3. Check for worn or damaged parts. 4. Adjust and/or replace if necessary.

Service item	Action
Pipes, valves, and other peripheral equipment	<ol style="list-style-type: none"> 1. Check for worn or damaged parts. 2. Adjust and/or replace if necessary.
Pump casing and impeller	<ol style="list-style-type: none"> 1. Check for worn or damaged parts. 2. Adjust and/or replace if necessary. <p>Wear on the impeller or surrounding parts necessitates fine adjustments of the impeller or replacement of worn parts. See Replace the impeller (page 32).</p>
Oil	<p>Check the water and oil mixture as follows:</p> <ol style="list-style-type: none"> 1. Insert a tube or hose into the oil hole. 2. Cover the top end of the tube. 3. Take up a little oil from the bottom. (Air/oil mixture can be confused with water/oil mixture.) 4. If the mixture contains too much water, in other words if it is heavily emulsified (creamlike) or if the water has settled out, then change the oil. See Change the oil (page 31). Check again one week after changing the oil.
Cable entry	<ol style="list-style-type: none"> 1. Check that the following requirements are met: <ul style="list-style-type: none"> • The cable clamps must be properly tightened. • The cable entry must be firmly tightened into its bottom-most position. • The seal sleeve and the washers must conform to the outside diameter of the cables. 2. Cut off a piece of the cable so that the seal sleeve closes around a new position on the cable. 3. Replace the seal sleeve, if necessary.
Inspection chamber ¹	<ol style="list-style-type: none"> 1. Check that the inspection screw is properly tightened. 2. Remove the inspection screw. 3. Drain all liquid, if any. 4. If there is oil in the inspection chamber, then check that the inner mechanical seal is not damaged. If necessary, contact an authorized service shop. 5. If there is water in the inspection chamber, then do the following: <ol style="list-style-type: none"> a. Check that the O-ring is not damaged. b. Check that the cable entry does not have any leakage.
Cable	<ol style="list-style-type: none"> 1. If the outer jacket is damaged, replace the cable. 2. Check that the cables do not have any sharp bends and are not pinched.
Cooling system	If the flow through the system has been partly restricted, then rinse and clean.
Level sensors or other sensor equipment	<ol style="list-style-type: none"> 1. Check the functionality. 2. Repair or replace any damaged equipment. 3. Clean and adjust the equipment.
Starter equipment	<ol style="list-style-type: none"> 1. Check the condition and functionality. 2. Contact an electrician, if necessary.

¹ Regardless of individual applications, the inspection chamber should not be inspected less frequently than the intervals for normal applications and operating conditions at media (liquid) temperatures <40°C (104°F).

Service item	Action
Insulation resistance in the stator	<ol style="list-style-type: none"> Check the insulation between: <ul style="list-style-type: none"> Phase-phase on the stator Phase-earth (ground) The insulation should be > 1 megohm. Use a 1000-VDC megger to test the insulation. If the resulting value is < 1 megohm, then contact an authorized service shop.

Major overhaul

For a major overhaul, take this action in addition to the tasks listed under Inspection.

Service item	Action
Support and main bearing	Replace the bearings with new bearings.
Mechanical seal	Replace with new seal units.

Change the oil

A paraffin oil with viscosity close to ISO VG32 is recommended. The pump is delivered from the factory with this type of oil. In applications where poisonous properties are of less concern, a mineral oil with viscosity up to ISO VG32 can be used.

Empty the oil

- Lay the pump on its side.
Lock the pump with supports to prevent it from rolling over.
- Remove the oil plug.
- Remove the oil screw.

There are two oil screws. Either screw can be used for drainage, but it is easier to drain the oil if both oil screws are removed.



WARNING:

The oil housing may be pressurized. Hold a rag over the oil plug to prevent oil from spraying out.

- Fit the oil drainage tube (optional).
The tube is included with the pump at delivery.
- Turn the pump so that the oil hole faces downwards and let the oil run out.

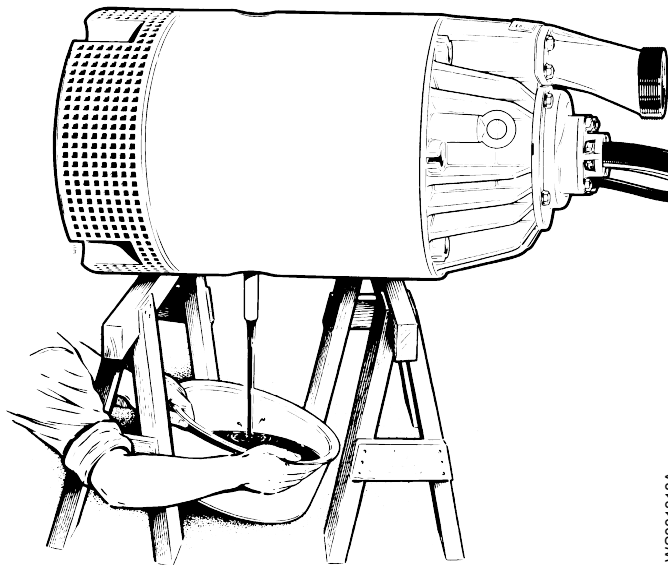

WS001318A

Fill with oil

1. Replace the oil screw O-ring.
2. Put one of the oil screws back and tighten it.
3. Put the corresponding oil plug back.
4. Turn the pump so that the oil hole faces upwards and fill with new oil.
Quantity: 5 L (5.3 qt.)

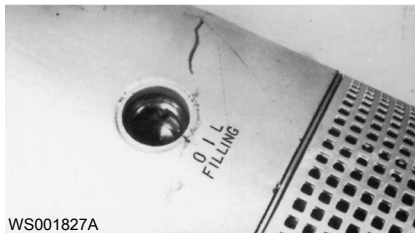

WS001827A

5. Put the oil screw back and tighten it.
Tightening torque: 10–20 Nm (7.4–15 ft-lbs)
6. Put the oil plug back.

Replace the impeller

Before you replace the impeller, you must drain the oil in the oil housing. See applicable steps in [Change the oil](#) (page 31).

Remove the impeller



WARNING:

A worn impeller and/or pump housing can have very sharp edges. Wear protective gloves.

1. Lay the pump on its side.
2. Remove the strainer:
 - a) Remove the nuts.
 - b) Remove the strainer.
3. Remove the diffuser:

- a) Remove the nuts.
- b) Remove the washers.
- c) Remove the diffuser.

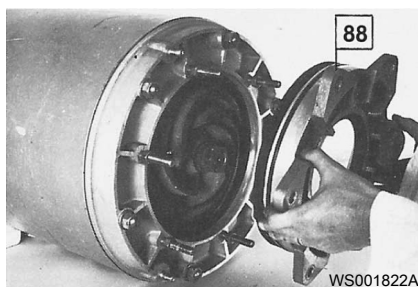

- d) Remove the O-ring.
4. Remove the impeller:
- a) Remove the impeller nut.
 - b) Remove the washer.
 - c) Pull off the impeller.
- Use an impeller puller or pry off carefully with two strong screwdrivers or bars.

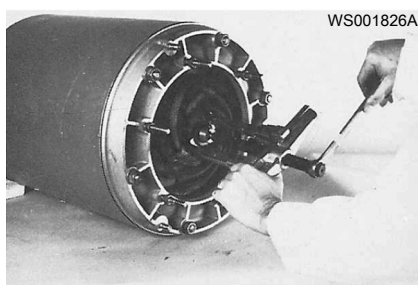

Install the impeller

1. Prepare the shaft:
 - a) Polish off any flaws with a fine emery cloth.
The end of the shaft must be clean and free from burrs.
 - b) Clean and oil all sealing surfaces and O-rings.
Do not use molybdenum disulphide (MoS_2).
 - c) Grease the end of the shaft and the impeller hub.
 - d) Insert the key in the keyway of the shaft.
 - e) Fit an appropriate number of adjusting washers on the shaft.



2. Check that the driving pin on the outer seal aligns with the key.

- Without turning the shaft in relation to the driving ring, push the impeller carefully so that the pin fits into the impeller keyway.

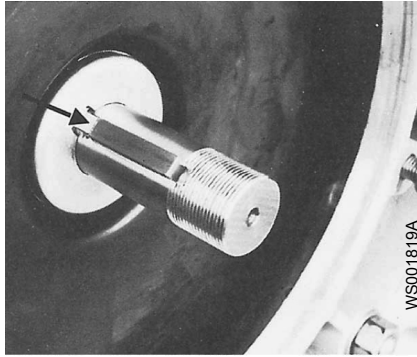

- Fit the washer and the nut.
- Tighten the impeller nut.
Tightening torque: 200 Nm (150 ft-lbs)

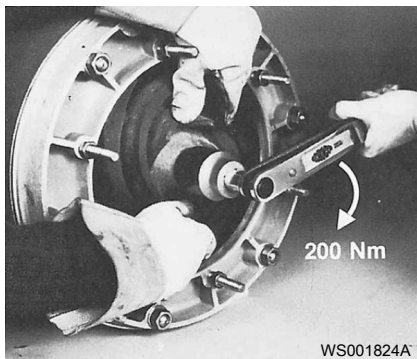

- Secure with washer.
- Check that the impeller can rotate easily.

Adjust the impeller

In order for the pump to perform at maximum capacity, the impeller must be adjusted regularly. The impeller clearance should be minimal when the impeller is tightened. Use the adjusting washers to adjust the clearance.

Version code 011 and 320: Pumps equipped with polyurethane covering are extremely resistant to wear. If the impeller does not rotate completely freely, the friction will generate a lot of heat. This can result in deformed wear parts, a stuck impeller, or damage to the pump. The impeller clearance should be 0.2-0.3 mm (0.008-0.012 in.) when the impeller is tightened.

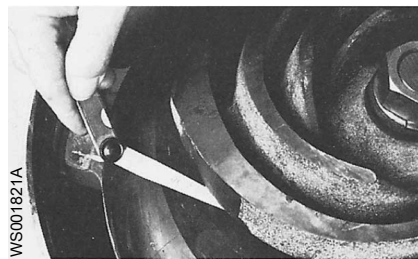

- Check that the impeller can rotate easily.
- Turn the adjusting nuts down to the bottom of the studs.
Version code 590 and 690, MT: Check that the spacers are seated on the studs.

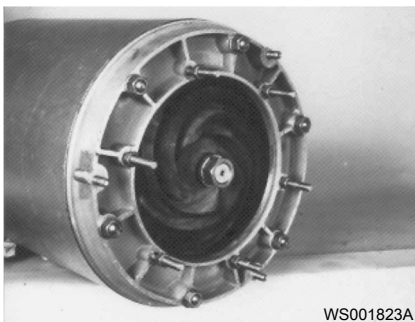

3. Fit the O-ring.
Version code 590 and 690: Fit the washers also.
4. Press the diffuser against the impeller.
5. Tighten the adjusting nuts so that they lie flush against the diffuser.

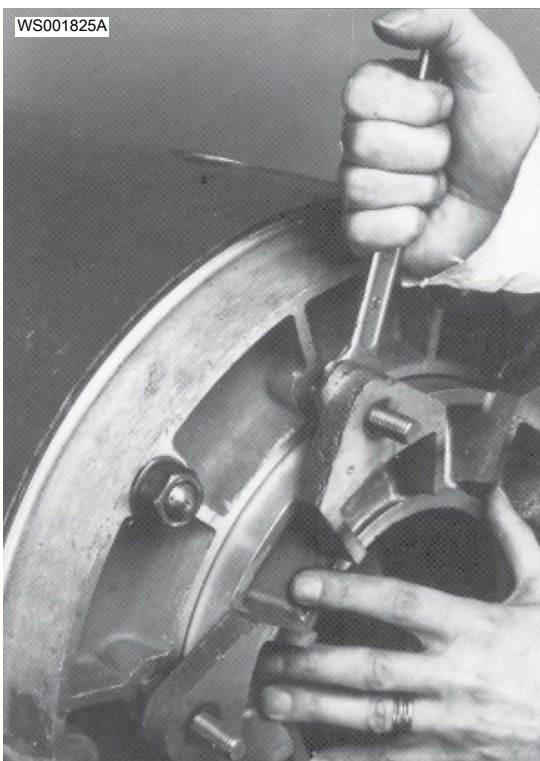

6. Back off all adjusting nuts another half turn (counterclockwise).
The impeller clearance should be minimal when the impeller is tightened. Use the adjusting washers to adjust the clearance.
7. Place washers and nuts on the studs. Tighten the nuts evenly all around.
8. Check that the impeller can rotate easily.
9. Version code 590 and 690: Lock the nuts with tab washers.
10. Install the strainer.

Replace the diffuser

1. Remove the diffuser:
 - a) Remove the impeller, see [Remove the impeller](#) (page 32).
 - b) Remove the nuts and washers.
 - c) Remove the diffuser.

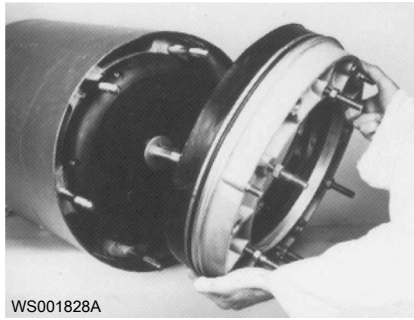

2. Install the diffuser:
 - a) Fasten the diffuser in place with the nuts and washers.
Tightening torque: 160-200 Nm (120-150 ft-lbs)
 - b) For further instructions, see [Install the impeller](#) (page 33).

Troubleshooting

Introduction

Follow these guidelines when troubleshooting the pump:

- Disconnect and lock out the power supply except when conducting checks that require voltage.
- Make sure that no one is near the pump when the power supply is reconnected.
- When troubleshooting electrical equipment, use the following:
 - Universal instrument multimeter
 - Test lamp (continuity tester)
 - Wiring diagram

The pump does not start



WARNING:

Always disconnect and lock out power before servicing to prevent unexpected startup. Failure to do so could result in death or serious injury.

NOTICE:

Do NOT override the motor protection repeatedly if it has tripped. Doing so may result in equipment damage.

Cause	Remedy
An alarm signal has been triggered on the control panel.	Check that: <ul style="list-style-type: none"> • The impeller rotates freely. • The sensor indicators do not indicate an alarm. • The overload protection is not tripped. If the problem still persists: Contact the local Xylem service shop.
The pump does not start automatically, but can be started manually.	Check that: <ul style="list-style-type: none"> • The start level regulator is functioning. Clean or replace if necessary. • All connections are intact. • The relay and contactor coils are intact. • The control switch (Man/Auto) makes contact in both positions. Check the control circuit and functions.
The installation is not receiving voltage.	Check that: <ul style="list-style-type: none"> • The main power switch is on. • There is control voltage to the start equipment. • The fuses are intact. • There is voltage in all phases of the supply line. • All fuses have power and that they are securely fastened to the fuse holders. • The overload protection is not tripped. • The motor cable is not damaged.
The impeller is stuck.	Clean:

Cause	Remedy
	<ul style="list-style-type: none"> • The impeller • The sump in order to prevent the impeller from clogging again.

If the problem persists, contact the local Xylem service shop. Always state the serial number of your pump when you contact Xylem, see [Product Description](#) (page 11).

The pump does not stop when a level sensor is used



WARNING:

Always disconnect and lock out power before servicing to prevent unexpected startup. Failure to do so could result in death or serious injury.

Cause	Remedy
The pump is unable to empty the sump to the stop level.	Check that: <ul style="list-style-type: none"> • There are no leaks from the piping and/or discharge connection. • The impeller is not clogged. • The non-return valve(s) are functioning properly. • The pump has adequate capacity. For information: Contact the local Xylem service shop.
There is a malfunction in the level-sensing equipment.	<ul style="list-style-type: none"> • Clean the level regulators. • Check the functioning of the level regulators. • Check the contactor and the control circuit. • Replace all defective items.
The stop level is set too low.	Raise the stop level.

If the problem persists, contact the local Xylem service shop. Always state the serial number of your pump when you contact Xylem, see [Product Description](#) (page 11).

The pump starts-stops-starts in rapid sequence

Cause	Remedy
The pump starts due to back-flow which fills the sump to the start level again.	Check that: <ul style="list-style-type: none"> • The distance between the start and stop levels is sufficient. • The non-return valve(s) work(s) properly. • The length of the discharge pipe between the pump and the first non-return valve is sufficiently short.
The self-holding function of the contactor malfunctions.	Check: <ul style="list-style-type: none"> • The contactor connections. • The voltage in the control circuit in relation to the rated voltages on the coil. • The functioning of the stop-level regulator. • Whether the voltage drop in the line at the starting surge causes the contactor's self-holding malfunction.

If the problem persists, contact the local Xylem service shop. Always state the serial number of your pump when you contact Xylem, see [Product Description](#) (page 11).

The pump runs but the motor protection trips



WARNING:

Always disconnect and lock out power before servicing to prevent unexpected startup. Failure to do so could result in death or serious injury.

NOTICE:

Do NOT override the motor protection repeatedly if it has tripped. Doing so may result in equipment damage.

Cause	Remedy
The motor protection is set too low.	Set the motor protection according to the data plate and if applicable the cable chart.
The impeller is difficult to rotate by hand.	<ul style="list-style-type: none"> • Clean the impeller. • Clean out the sump. • Check that the impeller is properly trimmed.
The drive unit is not receiving full voltage on all three phases.	<ul style="list-style-type: none"> • Check the fuses. Replace fuses that have tripped. • If the fuses are intact, notify a certified electrician.
The phase currents vary, or they are too high.	Contact the local Xylem service shop.
The insulation between the phases and ground in the stator is defective.	<ol style="list-style-type: none"> 1. Use an insulation tester. With a 1000 V DC megger, check that the insulation between the phases and between any phase and ground is > 5 megohms. 2. If the insulation is less: Contact the local Xylem service shop.
The density of the pumped fluid is too high.	<p>Make sure that the maximum density is 1100 kg/m³ (9.2 lb/US gal)</p> <ul style="list-style-type: none"> • Change the impeller, or • Change to a more suitable pump. • Contact the local Xylem service shop.
The ambient temperature exceeds the maximum ambient temperature.	The pump must not be used for such an application.
There is a malfunction in the overload protection.	Replace the overload protection.

If the problem persists, contact the local Xylem service shop. Always state the serial number of your pump when you contact Xylem, see [Product Description](#) (page 11).

The pump delivers too little or no water



WARNING:

Always disconnect and lock out power before servicing to prevent unexpected startup. Failure to do so could result in death or serious injury.

NOTICE:

Do NOT override the motor protection repeatedly if it has tripped. Doing so may result in equipment damage.

Cause	Remedy
The impeller rotates in the wrong direction.	<ul style="list-style-type: none"> • If it is a 3-phase pump, transpose two phase leads. • If it is a 1-phase pump: Contact the local Xylem service shop.
One or more of the valves are set in the wrong positions.	<ul style="list-style-type: none"> • Reset the valves that are set in the wrong position. • Replace the valves, if necessary. • Check that all valves are correctly installed according to media flow. • Check that all valves open correctly.
The impeller is difficult to rotate by hand.	<ul style="list-style-type: none"> • Clean the impeller. • Clean out the sump. • Check that the impeller is properly trimmed.
The pipes are obstructed.	Clean out the pipes to ensure a free flow.
The pipes and joints leak.	Find the leaks and seal them.
There are signs of wear on the impeller, pump, and casing.	Replace the worn parts.
The liquid level is too low.	<ul style="list-style-type: none"> • Check that the level sensor is set correctly. • Depending on the installation type, add a means for priming the pump, such as a foot valve.

If the problem persists, contact the local Xylem service shop. Always state the serial number of your pump when you contact Xylem, see [Product Description](#) (page 11).

Technical Reference

Application limits

Data	Description
Media (liquid) temperature	Maximum temperature 40°C (104°F)
pH of the pumped media (liquid)	Version code 320, 590, and 690: 6–11 Version code 011: 5–8
Media (liquid) density	Maximum density: 1100 kg/m ³ (9.2 lb. per US gal.)
Depth of immersion	20 m (65 ft.)
Other	For specific weight, current, voltage, power rating, and speed of the pump, see the data plate on the pump. For starting current, see Motor data (page 41). For other applications, contact the nearest Xylem representative for information.

Motor data

Feature	Description
Motor type	Squirrel-cage induction motor
Frequency	50 or 60 Hz
Supply	3-phase
Starting method	<ul style="list-style-type: none"> • Direct on-line • Star-delta
Maximum starts per hour	30 evenly spaced starts per hour
Code compliance	IEC 60034-1
Rated output variation	±10%
Voltage variation without overheating	±10%, provided that it does not run continuously at full load
Voltage imbalance tolerance	2%
Stator insulation class	H (180°C [360°F])

Specific motor data: Version code 011

3-phase, 50 Hz, MT, HT

Motor type:

- 2,920 rpm
- 37 kW (50 hp)

Voltage (V)	Rated current (A)	Starting current (A)
220	116	650

Voltage (V)	Rated current (A)	Starting current (A)
230	112	740
380	67	375
400	65	430
415	61	325
500	51	305
550	46	285

3-phase, 50 Hz, LT

Motor type:

- 1,465 rpm
- 30 kW (40 hp)

Voltage (V)	Rated current (A)	Starting current (A)
200	124	1020
220	111	880
230	98	745
380	62	505
400	56	430
415	56	410
500	46	325

3-phase, 60 Hz, MT, HT

Motor type:

- 3,500 rpm
- 43 kW (58 hp)

Voltage (V)	Rated current (A)	Starting current (A)
220	135	750
380	78	435
440	68	375
460	65	395
575	52	305

3-phase, 60 Hz, LT

Motor type:

- 1,760 rpm
- 37 kW (50 hp)

Voltage (V)	Rated current (A)	Starting current (A)
220	128	1,062
380	78	655
440	64	495
460	63	525
575	48	335

Specific motor data: Version code 320/590/690

3-phase, 50 Hz

Motor type:

- 2,900 rpm
- 37 kW (50 hp)

Voltage (V)	Rated current (A)	Starting current (A)
380 D	67	375
400 D	64	310
415 D	61	325
440 D	58	350
500 D	51	305
550 D	46	285
1,000 D	25	132
1,100 D	23	145

3-phase, 60 Hz

Motor type:

- 3,400 rpm
- 42.7 kW (57.2 hp)

Voltage (V)	Rated current (A)	Starting current (A)
440 D	68	375
460 D	65	395
575	52	305

Dimensions and weights

Version code 011

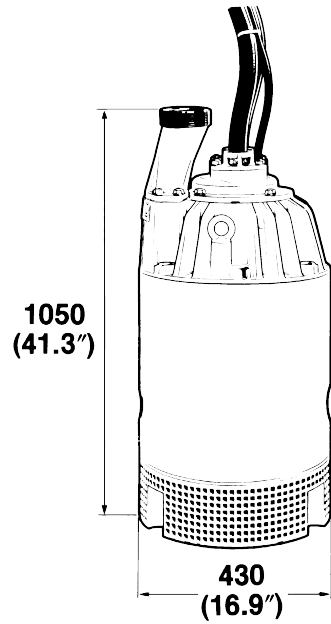

Figure 8: HT

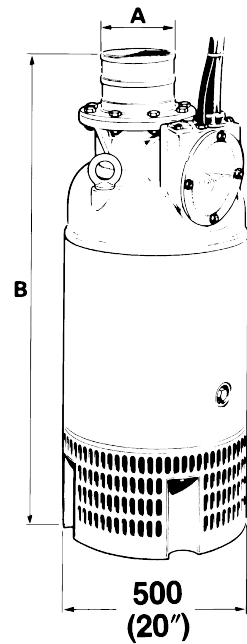

Figure 9: LT, MT

Dimension A describes either a threaded connection (begins with R) or a hose connection.

Table 3: Dimensions LT, MT

A	B
6 in. (152 mm)	1253 mm (49.3 in.)
8 in. (203 mm)	1253 mm (49.3 in.)

A	B
R6 = BSP.PI.6; NPT6	1153 mm (45.4 in.)
R8 = BSP.PI.8; NPT8	1153 mm (45.4 in.)

Table 4: Weight without motor cable

MT	280 kg (618 lbs)
HT	240 kg (530 lbs)
LT	285 kg (628 lbs)

Version code 320/590/690

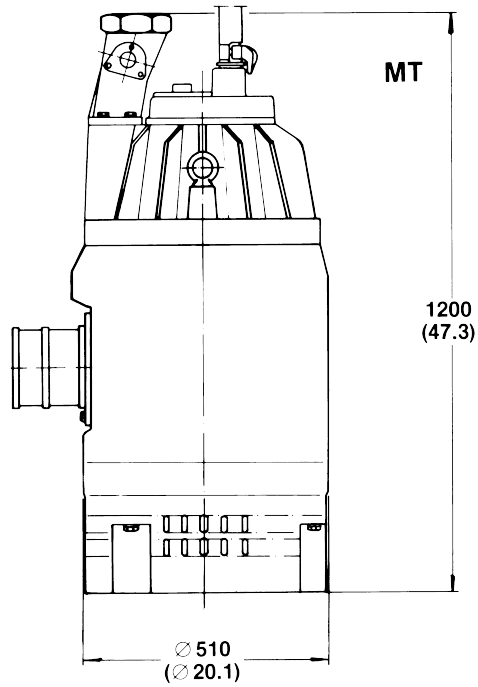

Figure 10: MT

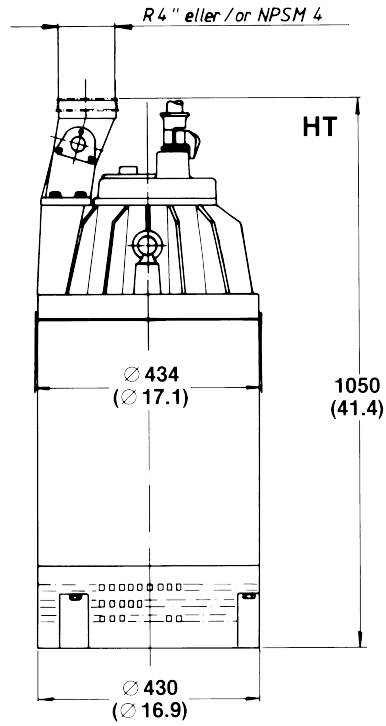

Figure 11: HT

Table 5: Weight without motor cable

MT	445 kg (980 lbs)
HT	350 kg (770 lbs)

Performance curves

Test standard

Pumps are tested in accordance with ISO 9906, HI level A.

Version code 011

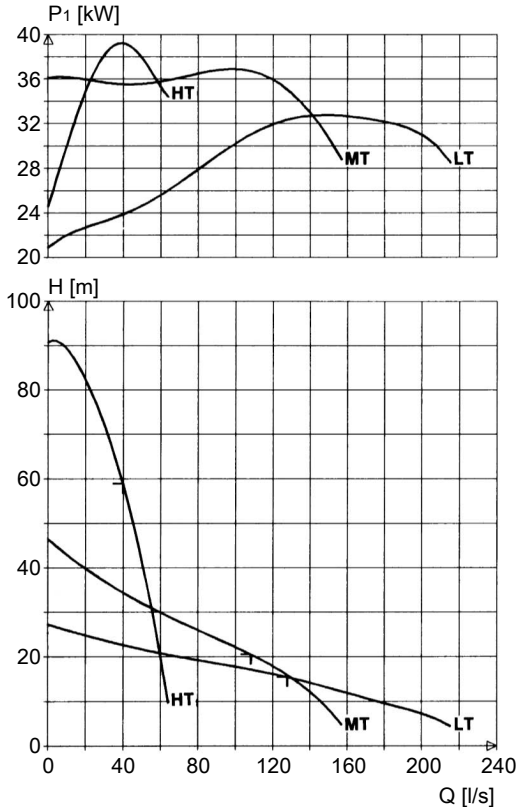

Figure 12: 50 Hz, LT, MT, HT

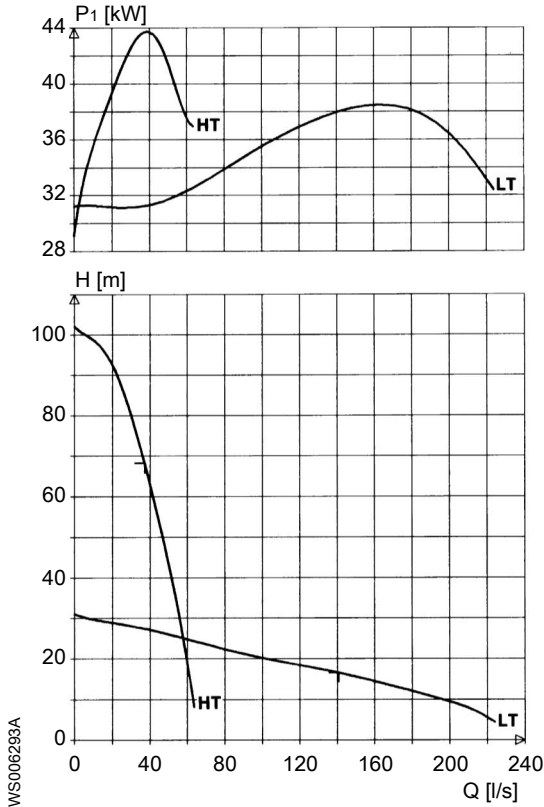

Figure 13: 60 Hz, LT, HT

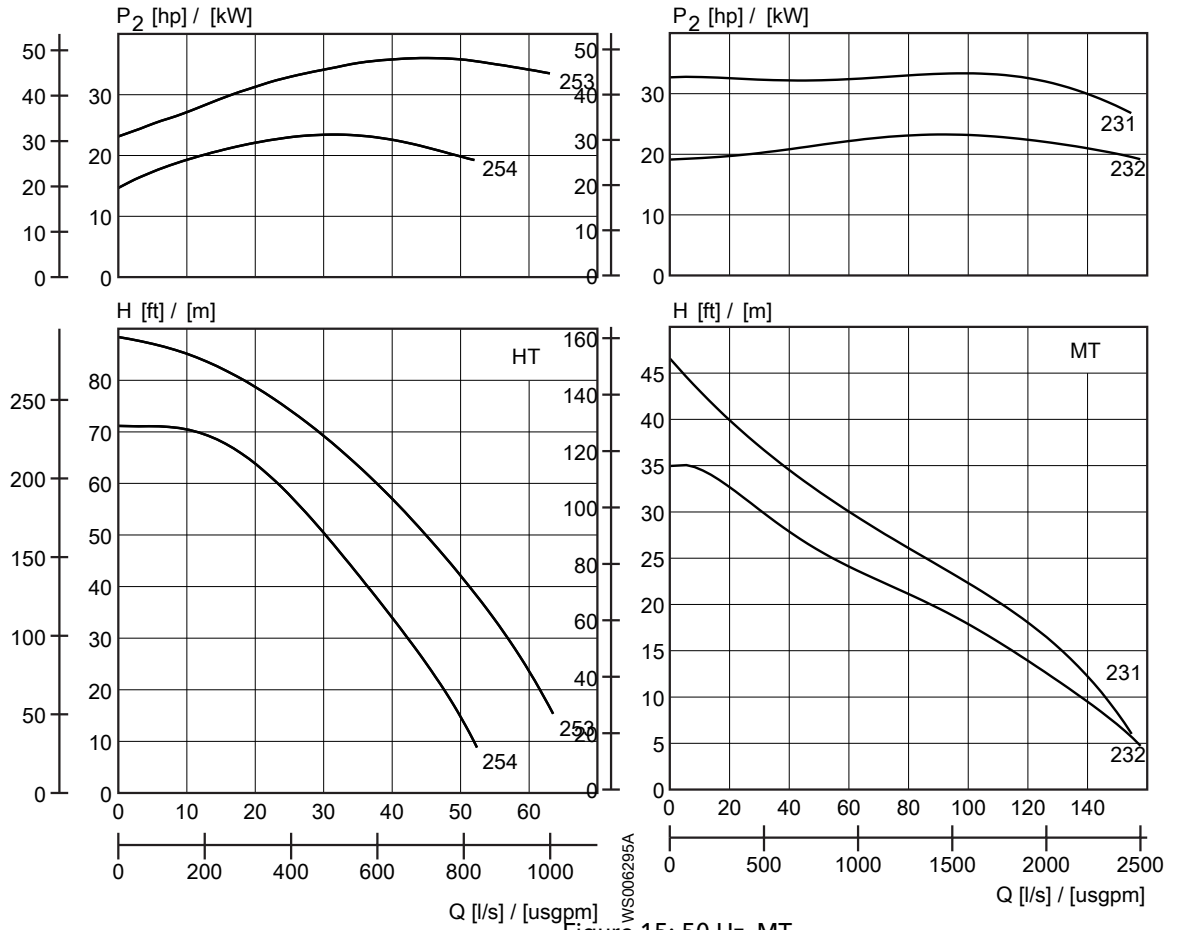

Figure 14: 50 Hz, HT

Figure 15: 50 Hz, MT

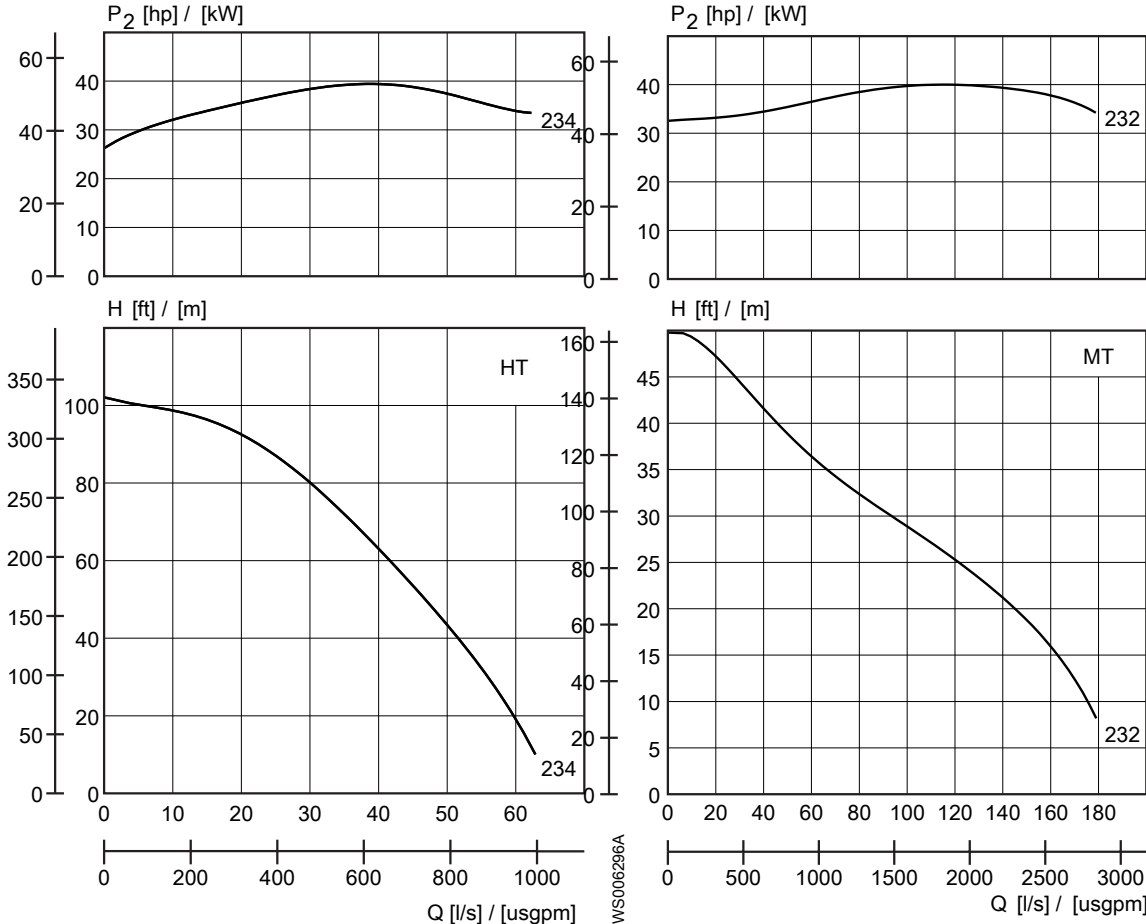

Figure 16: 60 Hz, HT

Figure 17: 60 Hz, MT

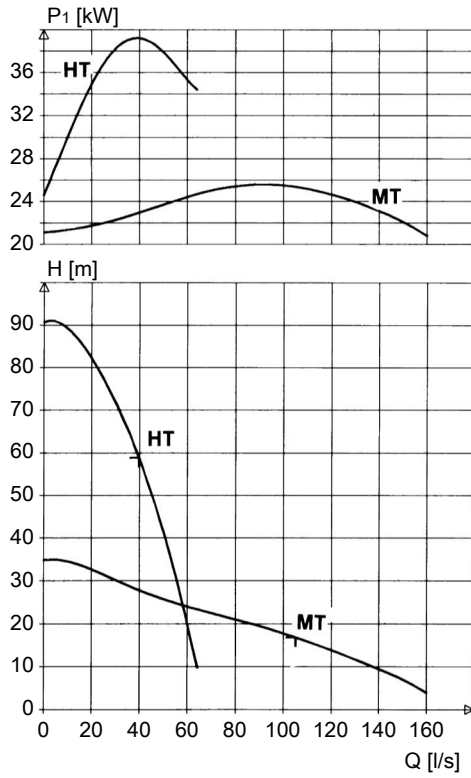

Figure 18: 50 Hz, 37 kW

WS006299A

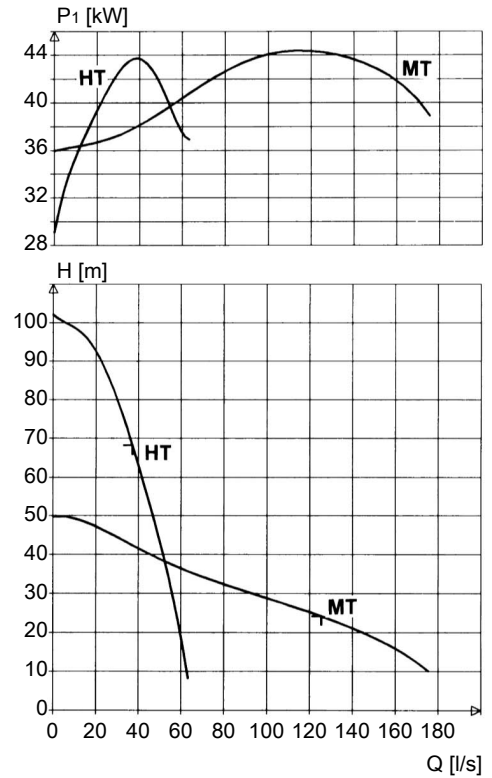

Figure 19: 60 Hz, 42.7 kW (58 hp)

A0036300A

Xylem |'zīləm|

- 1) The tissue in plants that brings water upward from the roots
- 2) A leading global water technology company

We're 12,500 people unified in a common purpose: creating innovative solutions to meet our world's water needs. Developing new technologies that will improve the way water is used, conserved, and re-used in the future is central to our work. We move, treat, analyze, and return water to the environment, and we help people use water efficiently, in their homes, buildings, factories and farms. In more than 150 countries, we have strong, long-standing relationships with customers who know us for our powerful combination of leading product brands and applications expertise, backed by a legacy of innovation.

For more information on how Xylem can help you, go to xylem.com



Xylem Water Solutions AB
Gesällvägen 33
174 87 Sundbyberg
Sweden
Tel. +46-8-475 60 00
Fax +46-8-475 69 00
<http://tpi.xylem.com>

Visit our Web site for the latest version of this document and more information

The original instruction is in English. All non-English instructions are translations of the original instruction.

© 2011 Xylem Inc.