

Flygt 2201.320

DEWATERING PUMP

50 Hz

Tough pumps for dewatering

The Flygt dewatering pumps from Xylem are designed for tough operating conditions. The pumps are ideal for applications in which the water or liquid contains high amounts of clay, stone chips, drilling fines etc, or to pump heavy sediment from tanks, sumps and containers.

This cast iron dewatering pump is designed for heavy-duty applications in which the liquids are corrosive, abrasive or contains salt water.

Our dewatering pumps are backed by an outstanding support and world-wide presence. Operating in over 150 countries we bring many years of experience to bear in order to keep your business moving.



FLYGT
a xylem brand

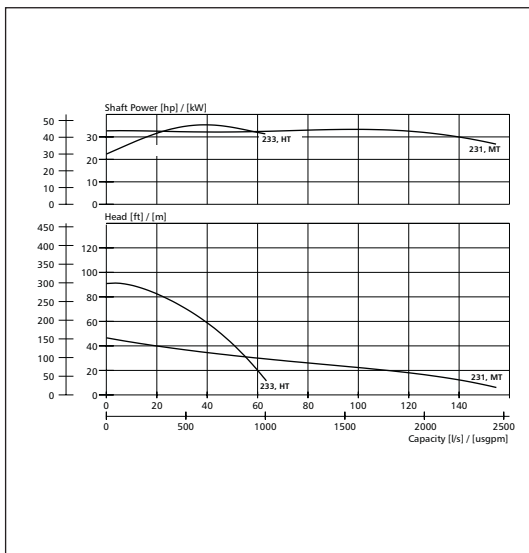
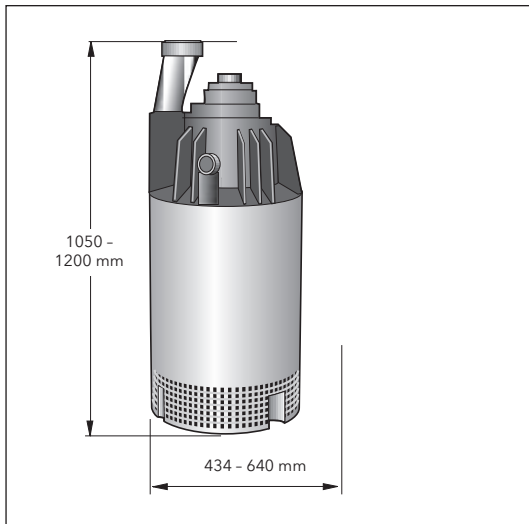

Voltage (V)	Rated current (A)	Starting current (A)
380	67	405
400	64	335
415	62	350
440	59	275
500	51	271
550	47	305

Product

Submersible pump for dewatering construction sites, draining water in flooded areas, handling water in mines or on oil platforms and other similar applications. The pump can handle water containing relatively abrasive solids.

Denomination

Product code	2201.320
Installation	S
Impeller characteristics	MT, HT
Discharge connection	4", 6", 8"

Process data

Liquid temperature	max +40 °C
Depth of immersion	max 20 m
The pH of the pumped liquid	pH 6 - 13
Liquid density	max 1100 kg/m ³
Strainer hole size, MT	(15 mm x 45 mm)
HT	(10 mm x 10 mm)

Motor data

Squirrel cage 3-phase induction motor.	
Frequency	50 Hz
Insulation class	F (+155° C)
Voltage variation	
- continuously running	max ± 5%
- intermittent running	max ± 10%
Voltage imbalance between phases	max 2%
No. of starts/hour	max 15

Monitoring equipment

Thermal contacts	
------------------	--

Cable

Direct-on-line and Y/D start	SUBCAB®
------------------------------	---------

Material

Outer casing	Cast iron
Impeller, MT	Alloyed white iron
HT	Spring steel, Stainless steel
Wear parts	Nitrile rubber
Stator housing	Cast iron
Strainer	Galvanized steel
Shaft	Stainless steel
O-rings	Nitrile rubber

Mechanical face seals

Inner	Corrosion resistant cemented carbide
Outer	Corrosion resistant cemented carbide

Weight

Total (excl. cable)	350 - 460 kg
---------------------	--------------

Options

Polyurethane-lined wear parts	POLY-LIFE®
Impeller (HT)	Stainless steel
Discharge connector with coupling A	
O-rings	Viton
Warm liquid version	
Various cable sizes	
Zinc anodes	
Tandem connection	

Accessories

Adapters, hose connections and other mechanical accessories. Electrical accessories such as pump controller, control panels, starters, monitoring relays, cables.

Rating

3~	
Rated output	37 kW
Speed of rotation	2930 rpm

xylem
Let's Solve Water

www.flygt.com
www.xyleminc.com